

**PLAN VIEW**

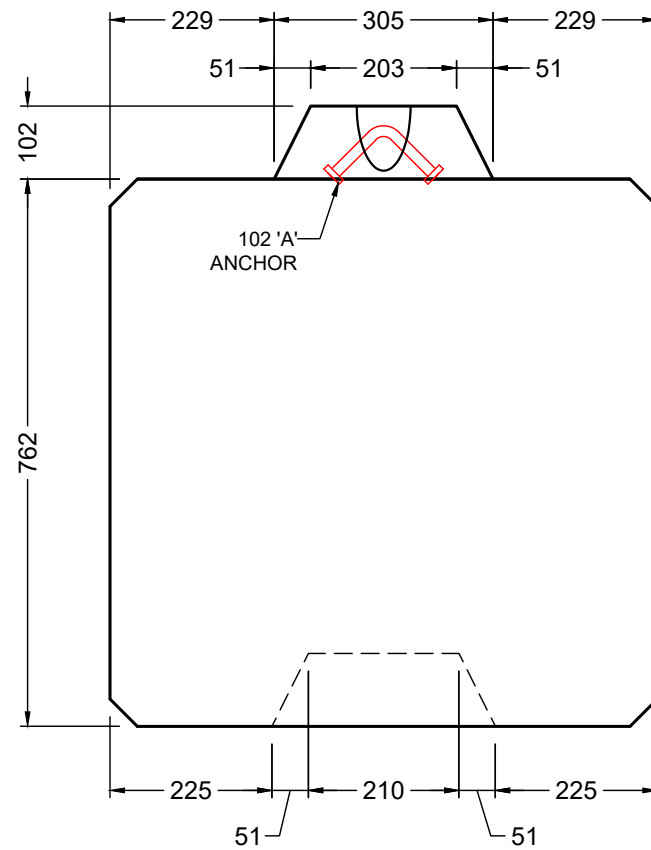

**SECTION A-A**

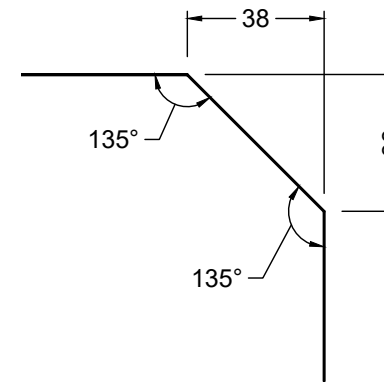

**CHAMFER DETAIL**

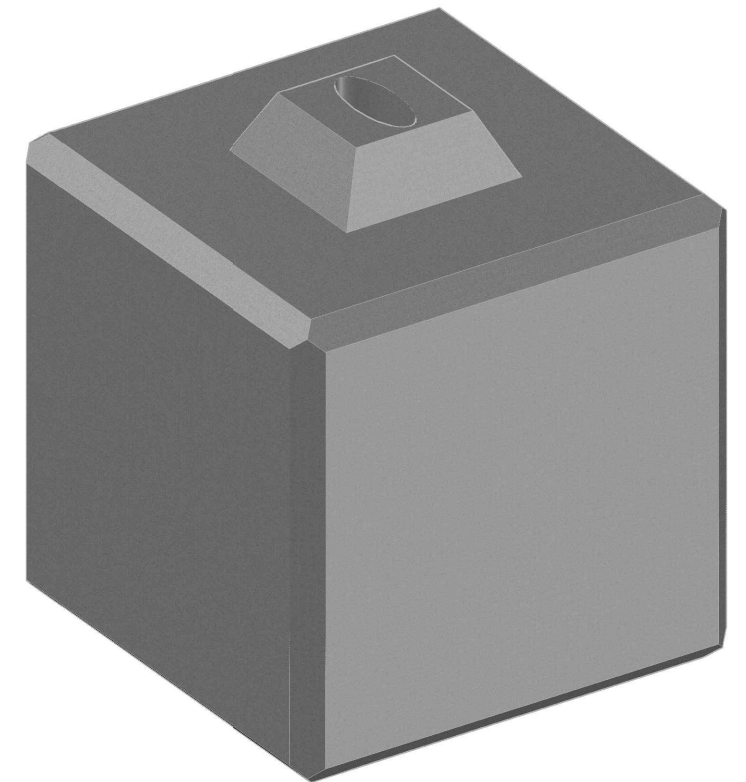

**ISOMETRIC VIEW**

**NOTES:**

- 1) CEMENT : PORTLAND CEMENT TYPE 50(HS)
- 2) Max AGGREGATE SIZE: 20mm
- 3) 28 DAY STRENGTH: MIN. 35 MPa.
- 4) ENTRAINED AIR: 6%±1%
- 5) ALL UNITS ARE IN MILLIMETERS UNLESS OTHERWISE NOTED.

**TOTAL WEIGHT = 1065 kg**



DWG. NO.	REFERENCE	NO.:	REVISION DESCRIPTION	BY	APP'D	DATE	DRW BY	SWM	2018/03/29
-	-	A	Plan Issued	SWM	-	2018/03/29	CH'K BY	-	-
-	-	-	-	-	-	-	AP'D BY	-	-
-	-	-	-	-	-	-	AP'D BY	-	-
-	-	-	-	-	-	-	AP'D BY	-	-
-	-	-	-	-	-	-	SCALE: NTS	-	-

TITLE:	762 x 762 x 762 BLOCK FORM DETAIL DRAWING
JOB NAME:	JOB NO.:
DRAWING NO.:	SVI-BF-762-01A

