

| A ID | B OD | C THK. | D HEIGHT | E JOINT HT. | F BASE | G TOP | H SPACING |
|------|------|--------|----------|-------------|--------|-------|-----------|
| 1219 | 1473 | 127    | 914      | 108         | 305    | 152   | 305       |
| 1219 | 1473 | 127    | 1219     | 108         | 610    | 152   | 305       |

| AVAILABLE HEIGHTS | QTY. OF RUNGS | STARCON LIFTING PINS | WEIGHTS [kg] |
|-------------------|---------------|----------------------|--------------|
| 0.92m [3']        | 3             | 4T                   | 998          |
| 1.22m [4']        | 4             | 4T                   | 1361         |

| CONCRETE | RELEASE      | MPa               | 20      |
|----------|--------------|-------------------|---------|
|          | 28 DAY:      | MPa               | 35      |
|          | AIR CONTENT: |                   | 6% ± 1% |
|          | WEIGHT:      | kg                |         |
|          | VOLUME       | m <sup>3</sup>    |         |
|          | TYPE:        | kg/m <sup>3</sup> | 2402    |

| STRAND |  | mm  | - |
|--------|--|-----|---|
|        |  |     |   |
|        |  | MPa | - |

| MARK | DESCRIPTION | QTY. |
|------|-------------|------|
|      |             |      |
|      |             |      |
|      |             |      |
|      |             |      |
|      |             |      |



ISOMETRIC VIEW  
NTS

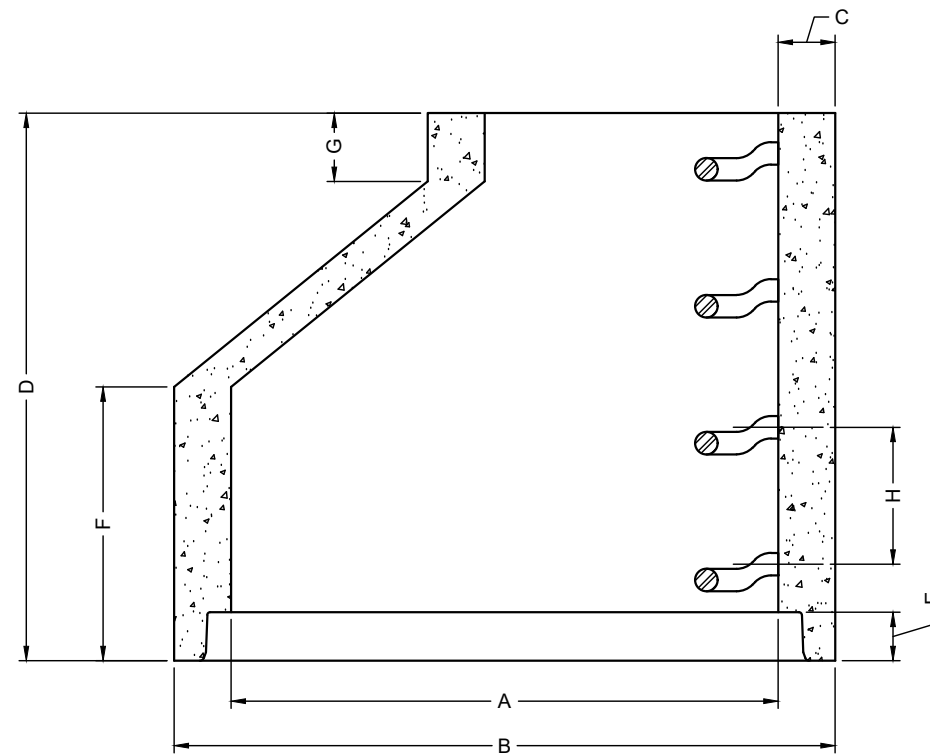

ELEVATION  
VIEW

NOTES:

- 1) CEMENT : PORTLAND CEMENT TYPE 50(HS)
- 2) Max AGGREGATE SIZE: 20mm
- 3) 28 DAY STRENGTH: MIN. 35 MPa.
- 4) ENTRAINED AIR: 6%±1%
- 5) REINFORCING TO CAN/CSA-G30.18 400 MPa
- 6) ALL UNITS ARE IN MILLIMETERS UNLESS OTHERWISE NOTED.

| DWG. NO. | REFERENCE | NO.: | REVISION DESCRIPTION | BY | APP'D | DATE       | DRW BY     | SWM          | 2018/11/21 |
|----------|-----------|------|----------------------|----|-------|------------|------------|--------------|------------|
| -        | -         | A    | ISSUED PLAN          | -  | -     | 2018/11/21 | CH'K BY    | -            | -          |
| -        | -         | -    | -                    | -  | -     | -          | AP'D BY    | -            | -          |
| -        | -         | -    | -                    | -  | -     | -          | AP'D BY    | -            | -          |
| -        | -         | -    | -                    | -  | -     | -          | AP'D BY    | -            | -          |
| -        | -         | -    | -                    | -  | -     | -          | SCALE: NTS | PAGE: 1 OF 1 |            |

| TITLE:       | 1200 X 1220<br>CONICAL TOP<br>DETAIL DRAWING |
|--------------|--|
| PROJECT NO.: | JOB NO.:                                     |
| DRAWING NO.: | SVI-MB-1200-01A                              |