

ISOMETRIC VIEW

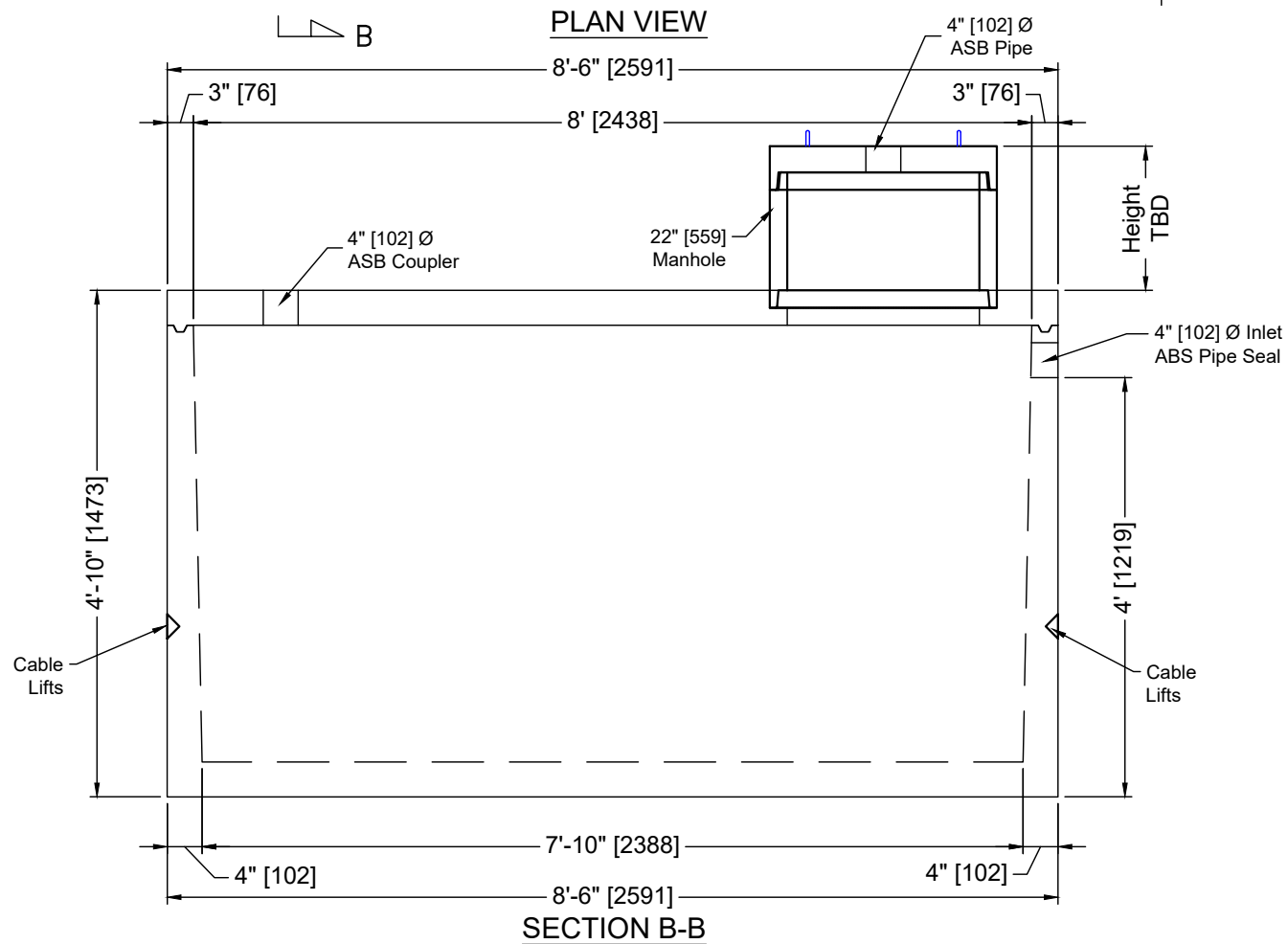

SECTION B-B

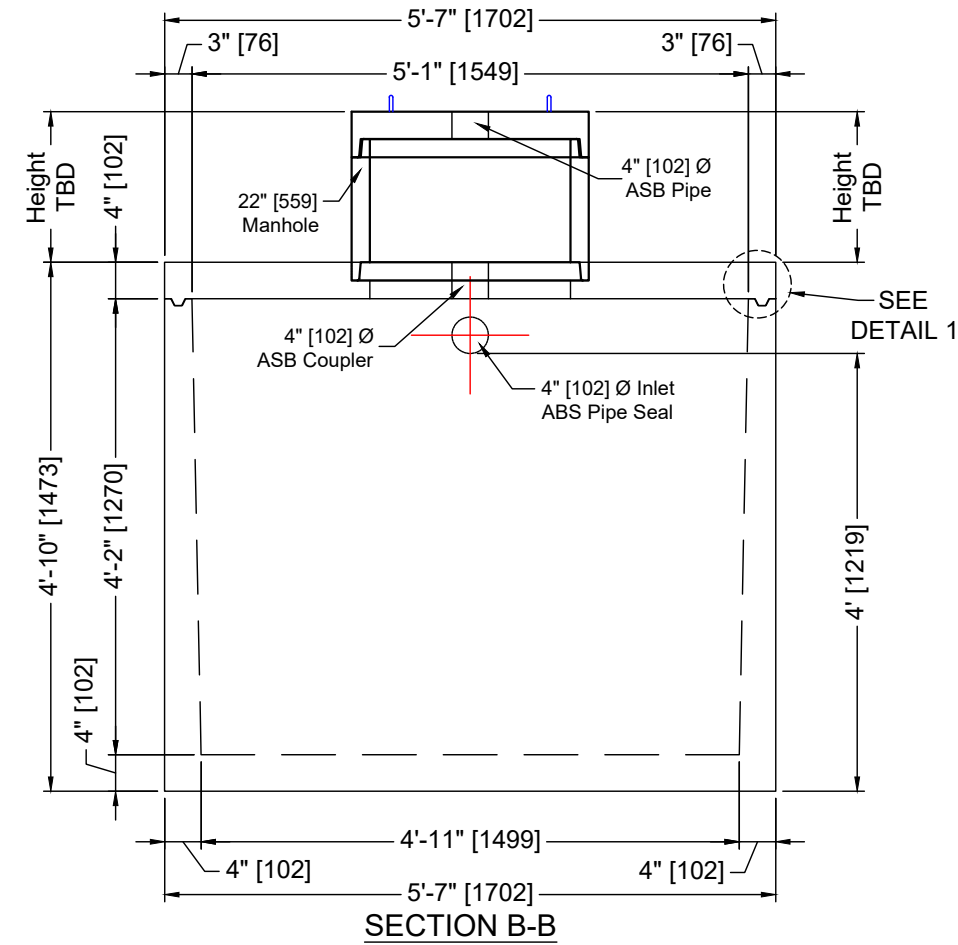

SECTION B-B

CONCRETE	RELEASE	MPa	20		
	28 DAY:	MPa	35		
	AIR CONTENT:		6% ± 1%		
	WEIGHT:	kg	4470	VOLUME	m ³
STRAND	TYPE:	kg/m ³	2402		
		mm	-		
		MPa	-		



Hwy 39 & Range Road 2150 - PO Box 521
Weyburn, SK S4H 2K3 - NE-25-08-15 W2M
WWW.SVIPRECAST.COM

Hwy 39 & Range Road 2150 - PO Box 521
Weyburn, SK S4H 2K3 - NE-25-08-15 W2M
WWW.SVIPRECAST.COM

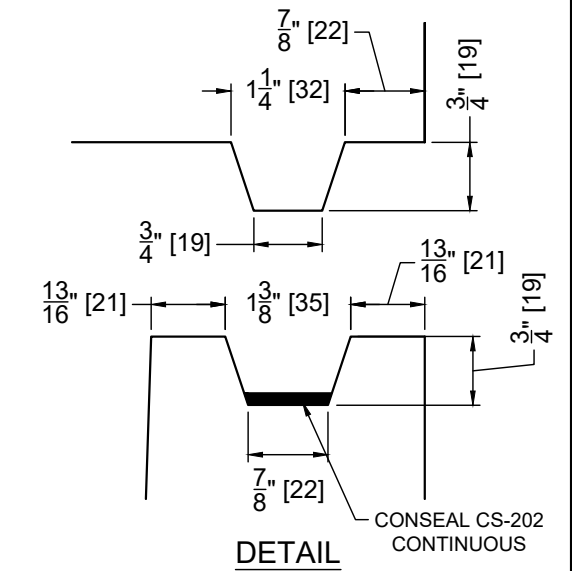

- NOTES:
- 1) CERTIFIED TO CSA B66-16
 - 2) MAX COVER = 7" (2133mm)
 - 3) CEMENT : PORTLAND CEMENT TYPE 50(HS)
 - 4) Max AGGREGATE SIZE: 20mm
 - 5) 28 DAY STRENGTH: MIN. 35 MPa.
 - 6) ENTRAINED AIR: 6%±1%
 - 7) REINFORCING TO CAN/CSA-G30.18 400 MPa
 - 8) ALL UNITS ARE IN MILLIMETERS UNLESS OTHERWISE NOTED.

DWG. NO.	REFERENCE	NO.:	REVISION DESCRIPTION	BY	APP'D	DATE	DRW BY	SWM	2020/11/16
-	-	A	ISSUED PLAN	-	-	2020/11/16	CH'K BY	-	-
-	-	-	-	-	-	-	AP'D BY	-	-
-	-	-	-	-	-	-	AP'D BY	-	-
-	-	-	-	-	-	-	SCALE: NTS	PAGE: 1 OF 1	

TITLE:	1000 Gallon Holding Tank DETAIL DRAWING	
PROJECT NO.:	JOB NO.:	
DRAWING NO.:	SVI-HT-1000-01A	